

**Illustrated
Parts List**

SINGER
INDUSTRIAL PRODUCTS

275 E1

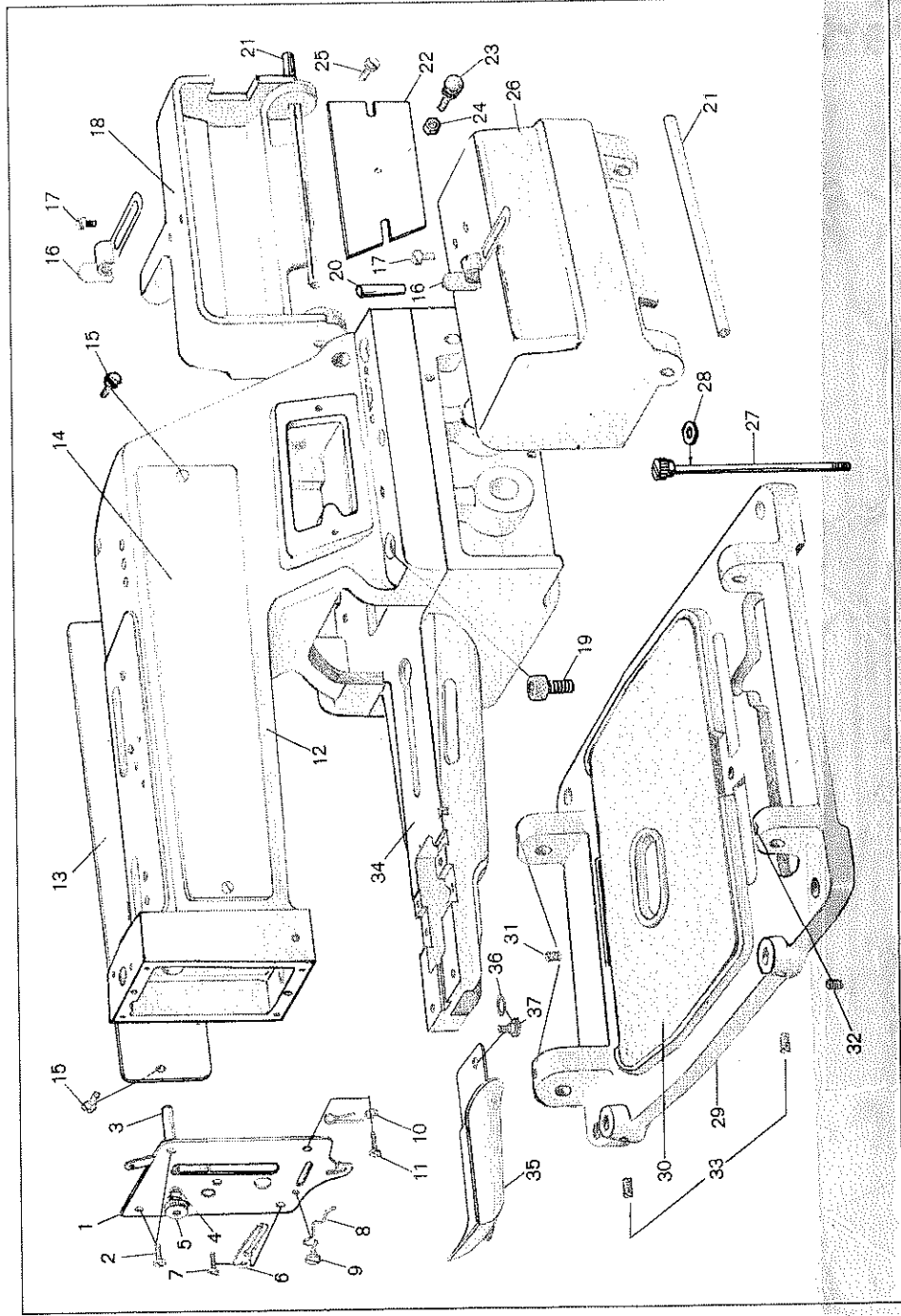

Ref. No.	Parts No.	Description
1	5055	Arm Front Cover
2	121-A	Screw for Front Cover 5055
3	5056-A	Nipper Releasing Plunger
4	5042	Spring for Plunger 5056-A
5	5056-B	Nut for Plunger 5056-A
6	5264	Thread Guide
7	121	Screw for Thread Guide 5264
8	5156	Thread Guide
9	5068	Screw for Thread Guide 5156
10	5079-B	Thread Guide
11	121	Screw for Thread Guide 5079-B
12	5001-S	Machine Arm
13	5205-S	Side Cover (Left)
14	5204-S	Side Cover (Right)
15	5233	Screw for Side Covers 5204 & 5205
16	5151	Spring for Covers 5004 & 5005
17	5276	Screw for Spring 5151
18	5005-S	Cover (Left)
19	5213	Screw for Arm & Bed
20	5214	Pin for Arm & Bed
21	5150	Hinge Shaft for Covers 5004 & 5005
22	5210-S	Model Plate Cover
23	5216	Knob Screw for Model Plate Cover 5210
24	5207	Nut for Knob Screw 5216
25	5233-A	Screw for Model Plate Cover 5210
26	5004-S	Cover for Stop Motion & Pulley (Right)
27	5153-B	Set Screw for Arm & Sub-Base
28	5275	Washer for Set Screw 5153-B
29	5003	Machine Sub-Base
30	5203	Felt
31	98	Screw for Hinge Shaft 5150 (Left)
32	132	Screw for Hinge Shaft 5150 (Right)
33	98	Screw for Pin Leg 5231
34	5002-S	Machine Bed
35	5147	Swing Cover
36	4140	Washer for Swing Cover 5147
37	4141	Screw for Swing Cover 5147

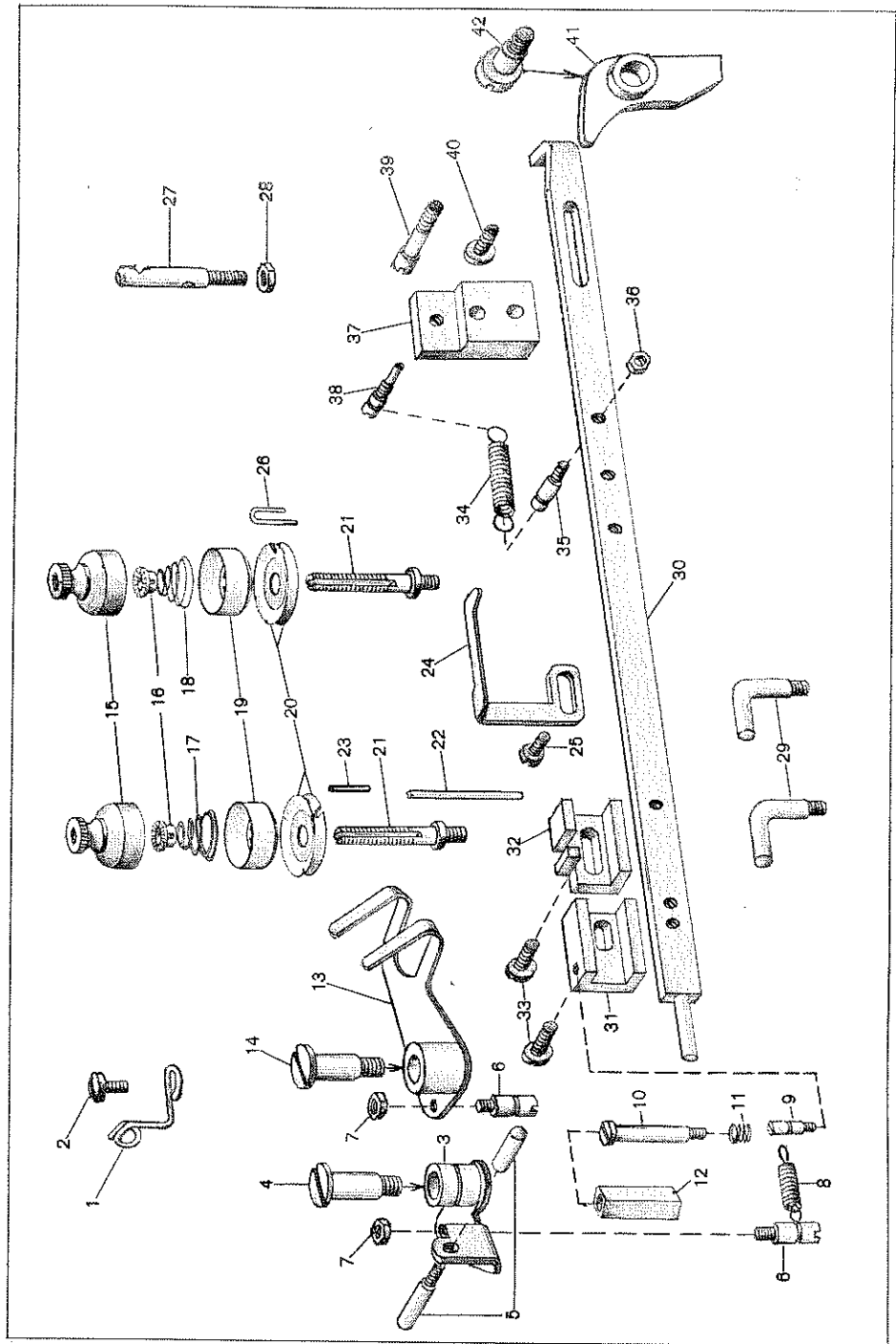

Ref. No.	Parts No.	Description
1	5077	Thread Guide
2	5176-A	Screw for Thread Guide 5077
3	5075	Thread Nipper
4	4096	Screw Stud for Thread Nipper 5075
5	5076	Thread Releasing Screw Stud
6	5074	Screw on Nipper 5075 & Lever 5073-A
7	5206	Nut for Screw 5074
8	5192	Spring for Block 5062
9	5223	Screw for Spring 5192
10	5160	Screw Stud for Block 5159
11	5161	Spring for Block 5159
12	5159	Nipper Block
13	5073-A	Thread Pull Off Lever
14	5236	Screw for Lever 5073-A
15	5272	Thread Tension Cap
16	5273	Stopper for Springs 5267-B & 79-C
17	5267-B	Thread Tension Spring (Front)
18	79-C	Thread Tension Spring (Rear)
19	5274	Thread Tension Cover
20	5190-A	Thread Tension Disc
21	5067-A	Thread Tension Staff
22	5071	Thread Tension Releasing Pin
23	5201	Thread Guide
24	5060	Thread Tension Releasing Lever
25	114	Screw for Lever 5060
26	5200	Thread Guide
27	5155-A	Thread Guide Stud
28	5207	Nut for Stud 5155-A
29	5072	Thread Guide
30	5059	Nipper Bar
31	5062	Nipper Bar Block (Front)
32	5061	Nipper Bar Block (Rear)
33	114	Screw for Blocks 5061 & 5062
34	5162	Nipper Bar Spring
35	5065	Screw for Spring 5162
36	5208	Check Nut for Screw 5065
37	5063	Nipper Bar Bearing Block
38	5064	Screw for Spring 5162
39	5188	Screw for Bearing Block 5063
40	5176-B	Screw for Bearing Block 5063
41	5057	Nipper Bar Moving Lever
42	5058	Screw for Lever 5057

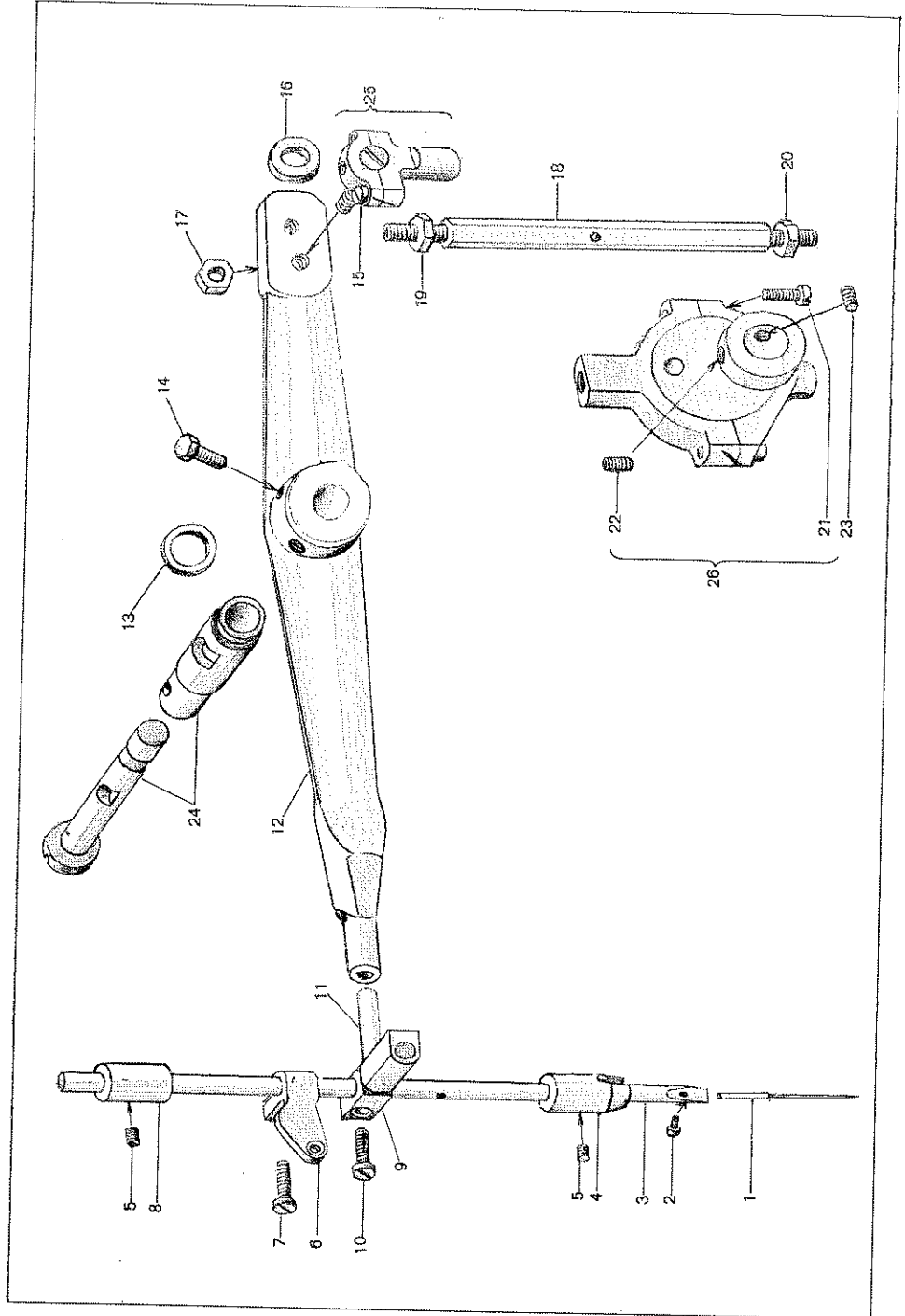

Ref. No.	Parts No.	Description
1	5232	Needle
2	5250	Needle Bar Screw
3	5054	Needle Bar
4	5053	Needle Bar Bushing (Lower)
5	5234	Screw for Bushings 5052 & 5053
6	5051	Thread Guide (Take-up)
7	121-C	Screw for Thread Guide 5051
8	5052	Needle Bar Bushing (Upper)
9	5050	Needle Bar Bearing Block Clamp
10	121-C	Screw for Clamp 5050
11	5049	Needle Bar Bearing Block
12	5043	Needle Bar Lever
13	5169	Spacing Washer
14	5220	Screw for Lever 5043
15	108	Screw for Top Ball Joint 582
16	5196	Washer for Top Ball Joint 582
17	4068	Nut for Top Ball Joint 582
18	5038-A	Needle Bar Lever Connecting Rod
19	5039-A	Nut for Connecting Rod 5038-A
20	5039-B	Nut for Connecting Rod 5038-A
21	105	Screw for Ball Joint Eccentric 507-B
22	5212-A	Screw for Ball Joint Eccentric 507-B
23	5251	Screw for Ball Joint Eccentric 507-B
24	594	Needle Bar Lever Shaft & Bushing
25	582	Top Ball Joint & Stud with (Ref. No.) 15
26	507-B	Ball Joint Eccentric with (Ref. Nos.) 21, 22 & 23

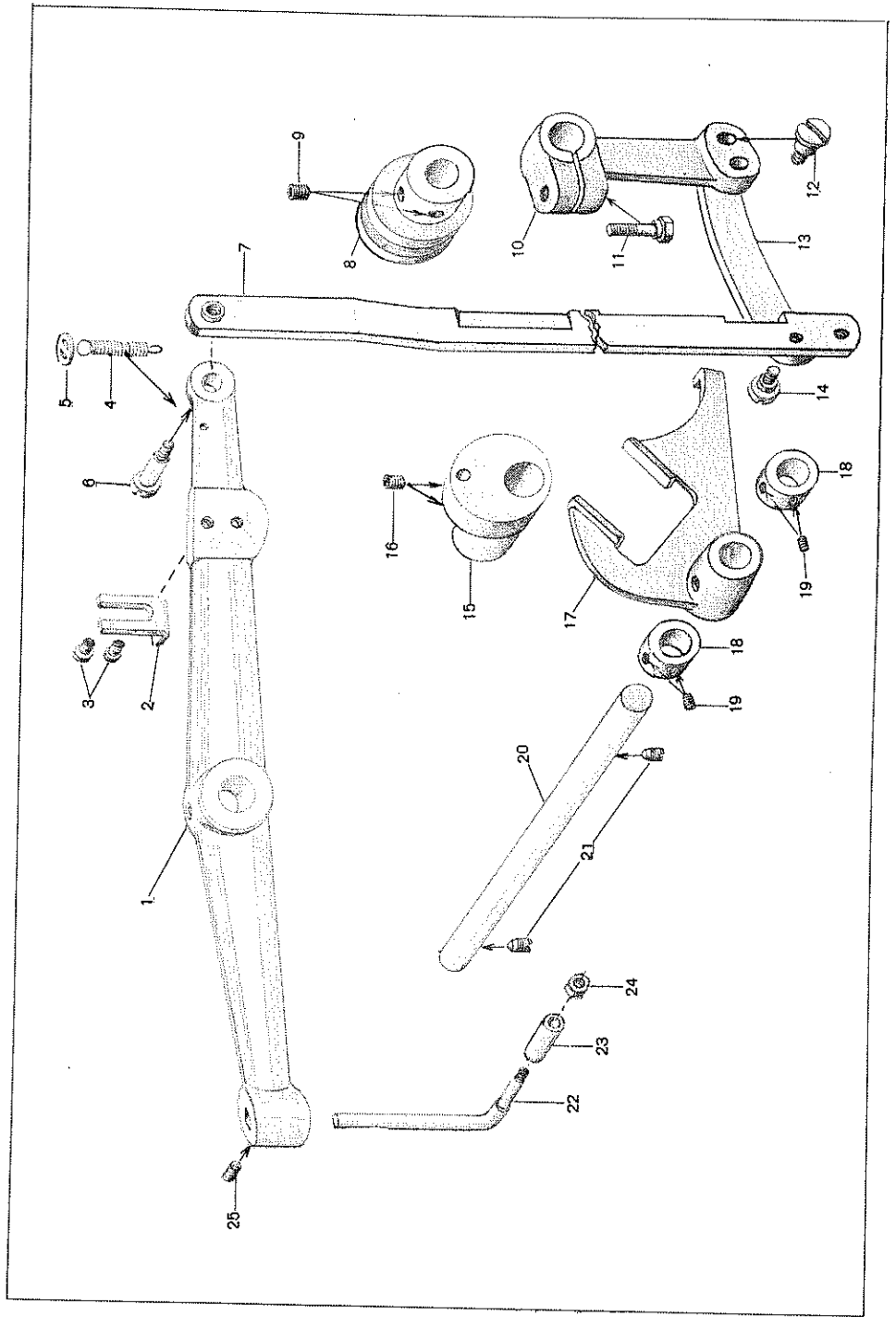

Ref. No.	Parts No.	Description
1	5046	Button Clamp Lifting Lever
2	5047-S	Button Clamp Lifting Lever Stop
3	5176-A	Screw for Stop 5047
4	5158	Spring for Lever 5046
5	5157	Washer for Spring 5158
6	5099	Shoulder Screw for Lever 5046
7	5066	Button Clamp Lifting Link
8	5028	Grooved Collar for Link 5066
9	132-A	Screw for Grooved Collar 5028
10	5140	Button Clamp Lifting Link Engaging Lever
11	4024	Screw for Lever 5140
12	5183-A	Shoulder Screw for Lever 5140
13	5141	Button Clamp Lifting Link Connecting Link
14	5217	Screw for Link 5141
15	5013	Button Clamp Lifting Lever Driving Eccentric
16	132-A	Screw for Eccentric 5013
17	5034	Button Clamp Eccentric Fork Lever
18	5036	Collar for Fork Lever 5034
19	130	Screw for Collar 5036
20	5035	Button Clamp Eccentric Fork Lever Shaft
21	5230	Screw for Shaft 5035
22	5048	Button Clamp Lifting Rod
23	5069	Button Clamp Lifting Rod Roll
24	5139	Nut for Roll 5069
25	98-A	Screw for Rod 5048

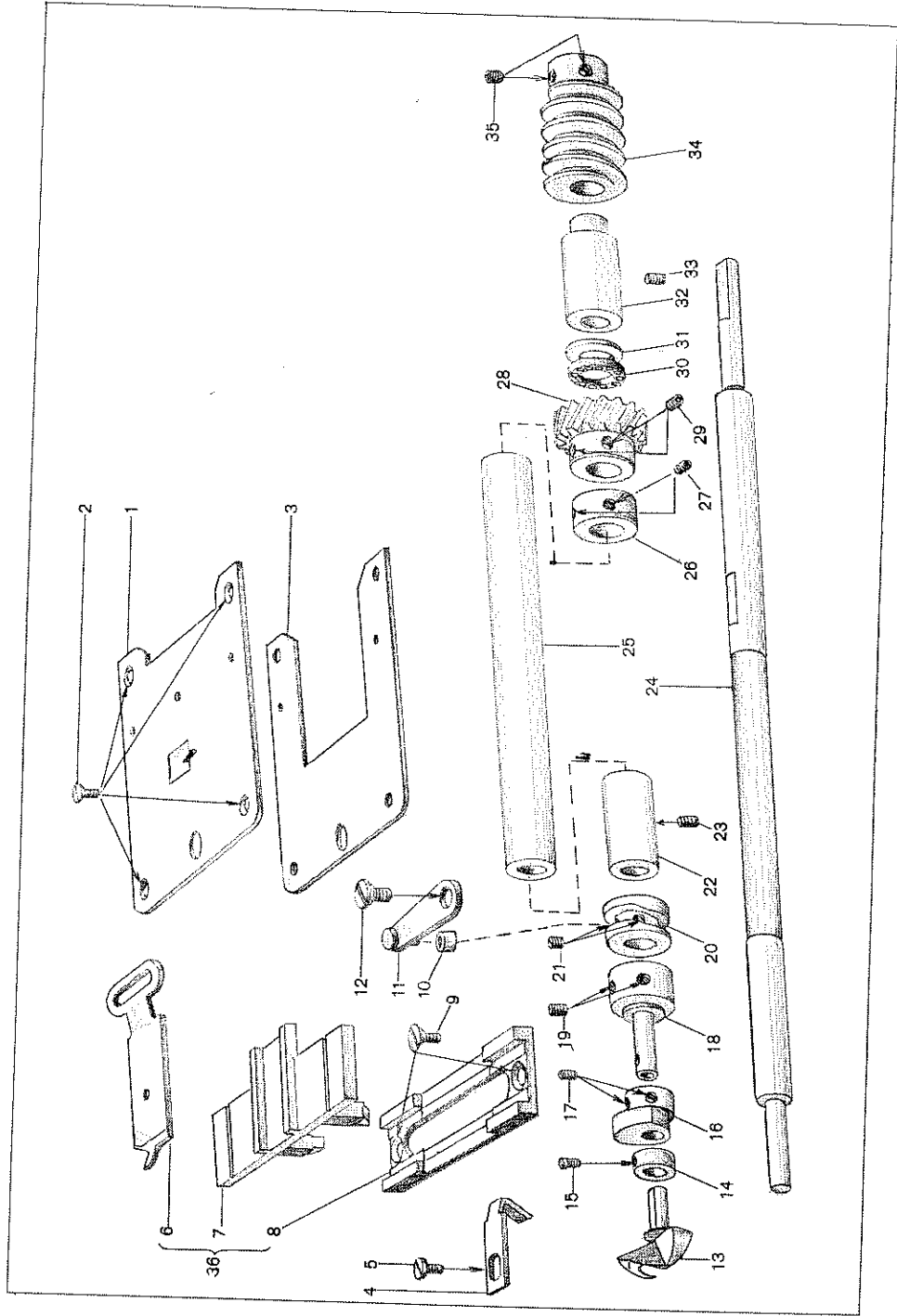

Ref. No.	Parts No.	Description
1	5129	Needle Plate
2	5221	Screw for Needle Plate 5129
3	5128	Spacer Plate
4	5127-A	Needle Guard
5	5176-A	Screw for Needle Guard 5127-A
6	5126-B	Loop Positioning Finger
7	5125	Positioning Finger Yoke Slide
8	5124	Yoke Slide Insert
9	5235	Screw for Insert 5124
10	5119	Loop Positioning Finger Lever Roll
11	5118	Loop Positioning Finger Lever
12	5184	Shoulder Screw for Lever 5118
13	5123	Looper
14	5122	Collar on Sleeve 5120
15	5263-A	Screw for Collar 5122
16	5121	Loop Positioning Finger Cam
17	129-B	Screw for Cam 5121
18	5120	Cam & Looper Sleeve
19	5225-C	Screw for Sleeve 5120
20	5117	Loop Positioning Finger Cam (Rear)
21	5225-B	Screw for Cam 5117
22	5111	Looper Shaft Front Bushing
23	131	Screw for Front Bushing 5111
24	5115-A	Looper Shaft
25	5265	Looper Shaft Tube
26	5266	Looper Shaft Collar
27	132-A	Screw for Collar 5266
28	5116	Looper Shaft Spiral Gear
29	5078-A	Screw for Spiral Gear 5116
30	5114	Looper Shaft Ball Bearing
31	5224	Washer for Ball Bearing 5114
32	5112-A	Looper Shaft Rear Bushing
33	98	Screw for Rear Bushing 5112-A
34	5113-A	Looper Shaft Worm
35	5251	Screw for Worm 5113-A
36	591	Loop Positioning Finger Complete (Ref. Nos.) 6, 7 & 8

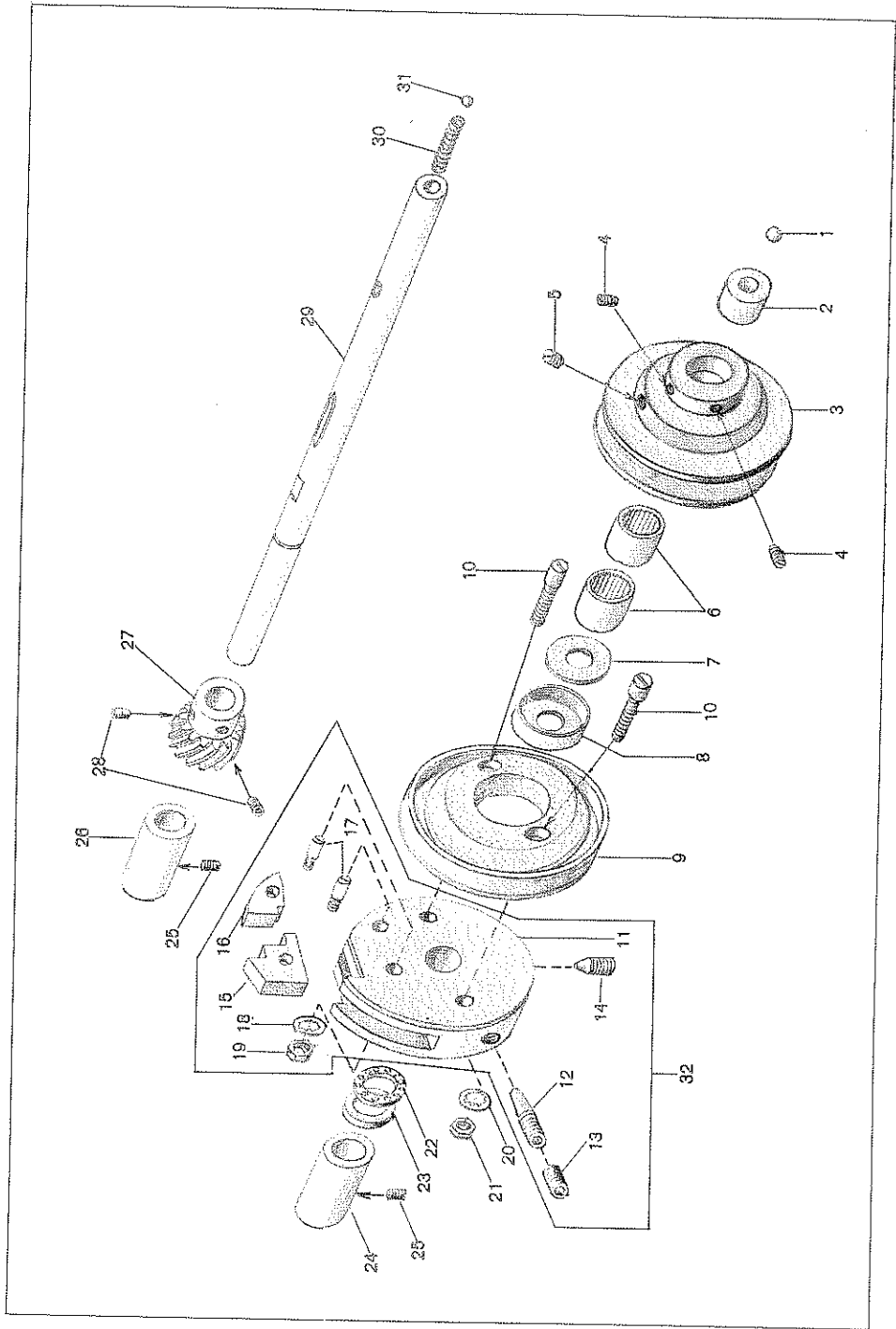

Ref. No.	Parts No.	Description
1	5020	Ball (Large)
2	5019	Pulley Insert
3	5016	Pulley
4	98	Set Screw for Insert 5019
5	95-B	Cap Screw
6	5017	Needle Bearing
7	5226	Felt for Needle Bearing 5017
8	5018	Washer for Felt 5226
9	5008-A	Stop Motion Clutch Disc
10	5152	Screw for Disc 5008-A
11	5007	Stop Motion Disc
12	5165-A	Spot Screw for Disc 5007
13	5215	Set Screw for Disc 5007
14	5165-C	Allen Screw for Disc 5007
15	5167	Stop Motion Disc Pawl
16	5168	Stop Motion Disc Latch
17	5187	Screw for Pawl 5167 & Latch 5168
18	5222-B	Washer for Screw 5187
19	4068	Nut for Screw 5187
20	5222-B	Washer for Screw 5152
21	4068	Nut for Screw 5152
22	5114	Ball Bearing
23	5224-A	Washer for Ball Bearing 5114
24	5009	Pulley Shaft Bushing (Right)
25	98	Screw for Bushings 5009 & 5010
26	5010	Pulley Shaft Bushing (Left)
27	5012	Pulley Shaft Spiral Gear
28	5251	Screw for Spiral Gear 5012
29	5006	Pulley Shaft
30	5022	Spring
31	5021	Ball (Small)
32	555	Stop Motion Disc Complete (Ref. Nos.) 11~19

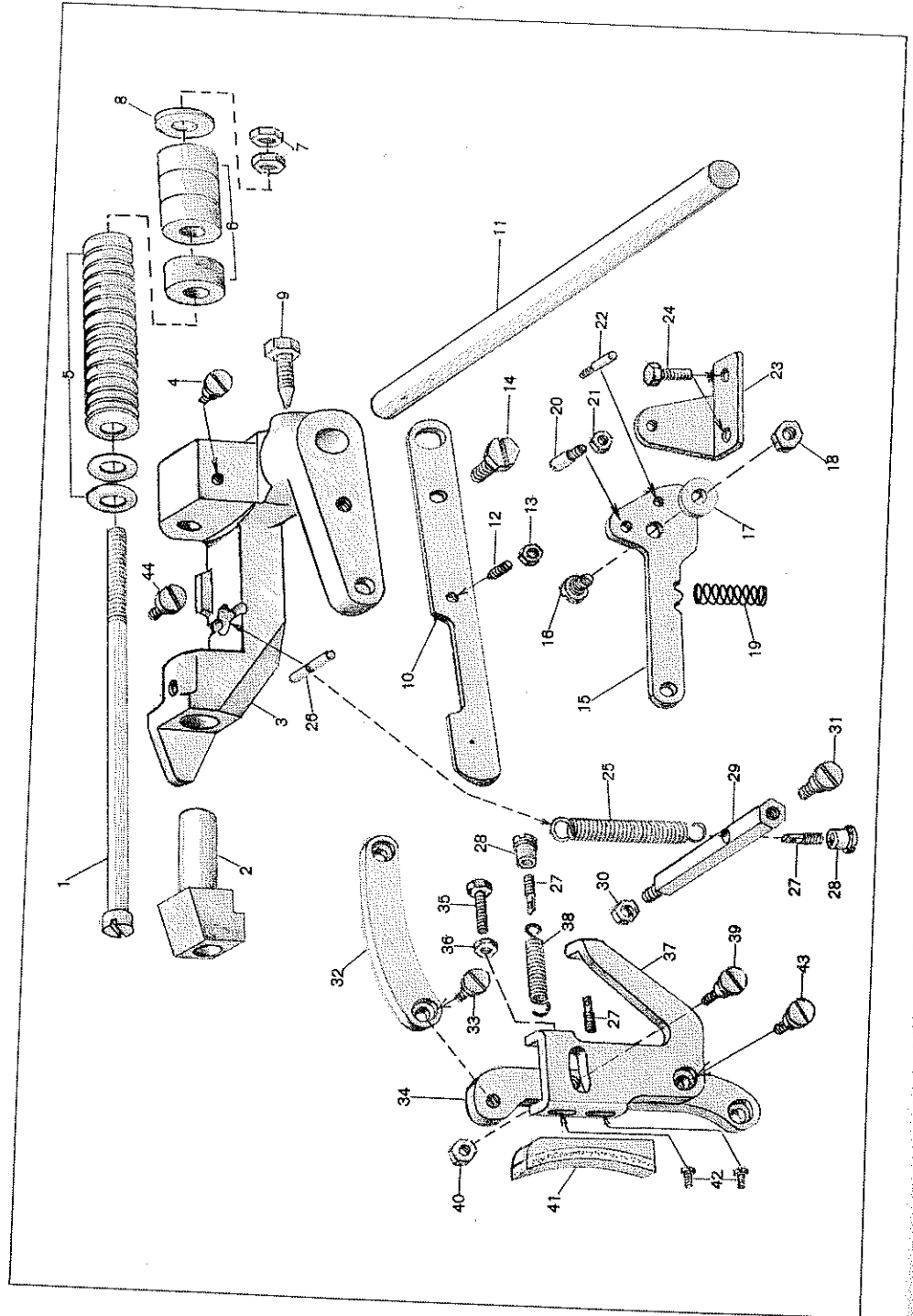

Ref. No.	Parts No.	Description
1	5134	Stop Motion Plunger Rod
2	5133	Stop Motion Plunger
3	5130-A	Stop Motion Plunger Lever
4	5247-A	Screw for Lever 5240
5	5135	Stop Motion Disc Spring
6	5136	Rubber Washer
7	5039-A	Adjusting Nut for Disc Spring 5135
8	5249	Washer for Nut 5039-A
9	5185	Spot Screw for Lever 5130-A
10	5131	Stop Motion Adjusting Lever
11	5132	Stop Motion Trip Lever Shaft
12	4009	Screw for Lever 5131
13	5271	Nut for Screw 4009
14	5198	Hexagon Screw for Lever 5131
15	5163	Stop Motion Trip Lever
16	4050	Screw for Trip Lever 5163
17	5070	Washer for Screw 4050
18	4068	Nut for Screw 4050
19	5193	Spring for Trip Lever 5163
20	5199	Stop Screw for Trip Lever 5163
21	5207	Nut for Stop Screw 5199
22	5187	Stopper for Trip Lever 5163
23	5164	Stop Motion Trip Lever Bracket
24	5177	Screw for Bracket 5164
25	5137-B	Stop Motion Lever Restoring Spring
26	5197	Pin for Spring 5137-B
27	4094	Screw for Springs 5137-B & 4093-B
28	4095	Nut for Screw 4094
29	5237	Screw Stud for Spring 5137-B
30	4068	Nut for Screw Stud 5237
31	5247-A	Screw for Stud 5237 & Lever 5242
32	5240	Brake Actuating Lever
33	5247-A	Connecting Screw for Lever 5240
34	5242	Brake Supporting Lever
35	5238	Brake Regulating Screw
36	5277	Nut for Screw 5238
37	5241	Bracket for Lever 5242
38	4093-B	Brake Spring
39	4178	Adjusting Thumb Screw for Lever 5242
40	5207	Nut for Screw 4178
41	5243	Brake Lining
42	115	Set Screw for Brake Lining 5243
43	5247-A	Set Screw for Bracket 5241
44	5194	Screw for Lever 5130-A

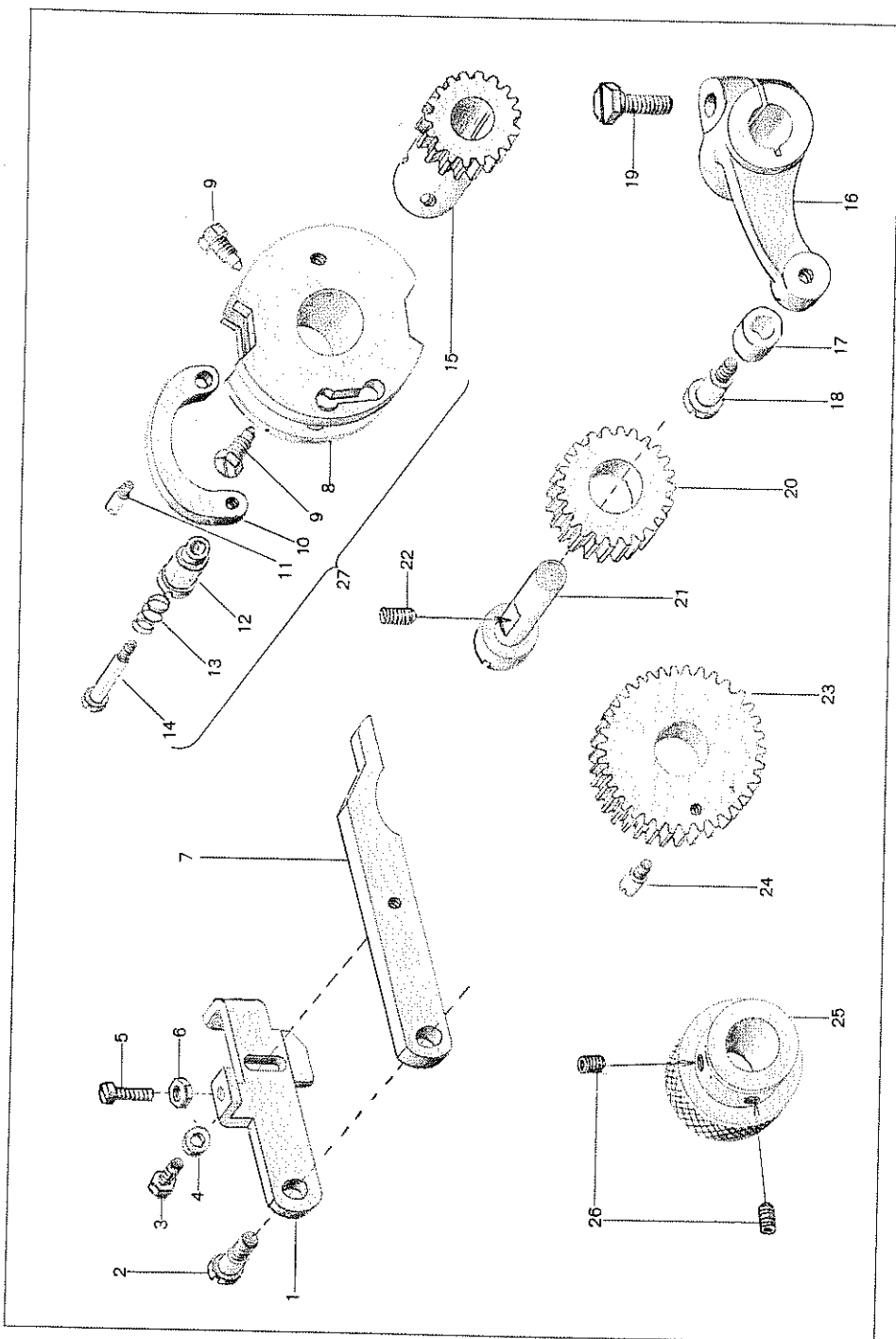

Ref. No.	Parts No.	Description
1	5146	Stitch Selecting Latch
2	5099	Screw for Latch 5146
3	5218	Screw for Latch 5146
4	5178	Washer for Screw 5218
5	5211	Stop Screw for Latch 5146
6	5206	Nut for Stop Screw 5211
7	5145	Stitch Selecting Lever
8	5031	Stop Motion Cam
9	5171-A	Set Screw for Cam 5031
10	5170	Stop Motion Cam Shoe
11	5172	Hinge Screw for Shoe 5170
12	5173	Stop Motion Cam Knob
13	5175	Spring for Knob 5173
14	5174	Screw for Knob 5173
15	5030	Stop Motion Gear
16	5142	Stop Motion Tripping Lever
17	5143	Cam Roll for Lever 5142
18	5144	Screw for Cam Roll 5143
19	5186	Clamp Screw for Lever 5142
20	5032	Stitch Selecting Spur Gear, Intermediate
21	5033	Bearing Pin for Spur Gear 5032
22	131	Screw for Bearing Pin 5033
23	5014	Stitch Selecting Spur Gear
24	5270	Screw for Spur Gear 5014
25	5015	Hand Knob
26	132-A	Screw for Hand Knob 5015
27	596	Stop Motion Cam Complete (Ref. Nos.) 8~15

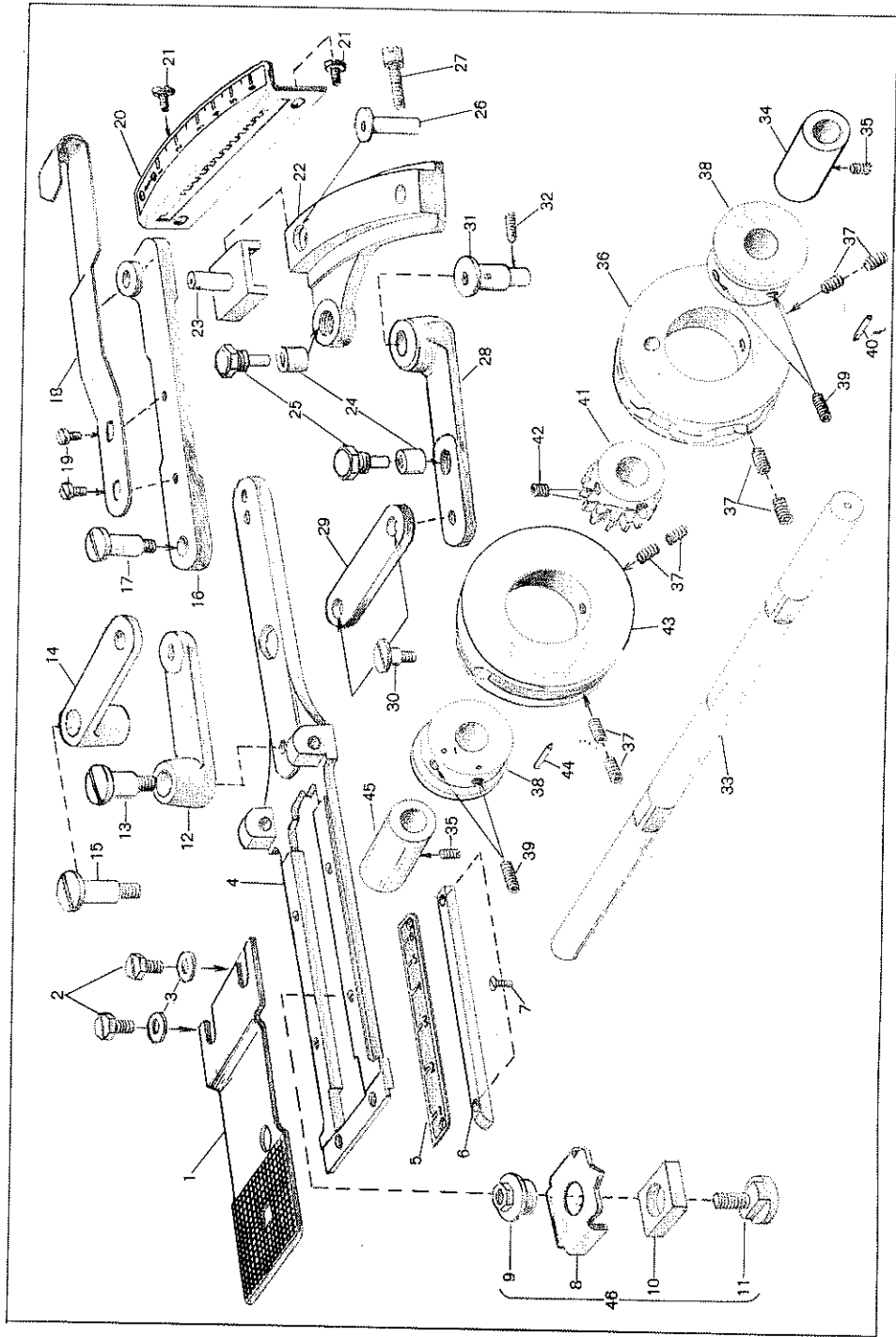

Ref. No.	Parts No.	Description
1	5085-A	Feed Plate for Flat Button
2	5176-C	Screw for Feed Plate 5085-A
3	5178	Washer for Screw 5176-C
4	5080	Button Clamp Slide Plate
5	5149	Sideways Moving Graduated Plate
6	5148	Block for Graduated Plate 5149
7	5191	Screw for Graduated Plate 5149
8	5084	Sideways Moving Indicator
9	5083	Fulcrum Nut for Indicator 5084
10	5082	Bearing Block for Indicator 5084
11	5081	Screw for Indicator 5084
12	5103	Slide Plate Connecting Link
13	5104-A	Screw for Link 5103
14	5105	Slide Plate Intermediate Connecting Link
15	5104-B	Screw for Link 5105
16	5106	Handle & Indicator Spring Connecting Link
17	5219	Screw for Link 5106
18	5107	Handle & Indicator Spring
19	5229	Screw for Spring 5107
20	5108	Lengthwise Moving Graduated Plate
21	5227	Screw for Graduated Plate 5108
22	5109	Lengthwise Moving Lever
23	5110	Slide Block for Lever 5109
24	5101	Cam Roller
25	5100	Screw for Cam Roller 5101
26	5102	Bearing Pin for Lever 5109
27	5245	Screw for Bearing Pin 5102
28	5098	Sideways Moving Lever
29	5097	Sideways Moving Lever Link
30	5183-A	Screw for Link 5097
31	5228	Pin for Lever 5098
32	131	Screw for Pin 5228
33	5023	Cam Shaft
34	5024-A	Cam Shaft Bushing (Right)
35	98	Screw for Bushings 5024-A & 5025-A
36	5026-A	Sideways Moving Cam
37	5195-B	Screw for Cams 5026-A & 5029-A
38	5252	Cam Boss
39	5254	Screw for Cam Boss 5252
40	5256	Cam Indicating Pin (Right)
41	5027	Cam Shaft Worm Gear
42	5078-A	Screw for Worm Gear 5027
43	5029-A	Lengthwise Moving Cam
44	5255	Cam Indicating Pin (Left)
45	5025-A	Cam Shaft Bushing (Left)
46	586-T	Sideways Moving Indicator Complete (Ref. Nos.) 8, 9, 10 & 11

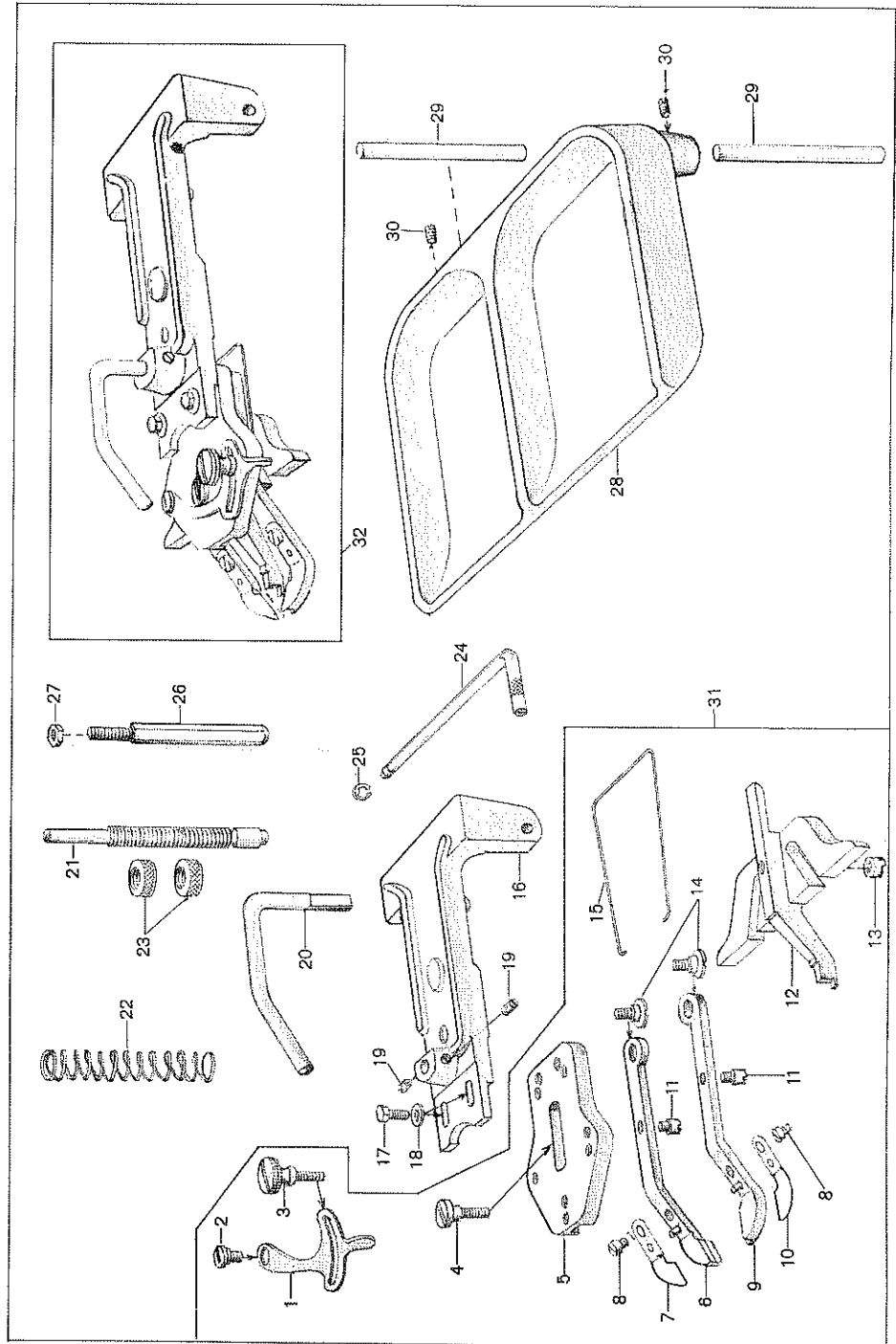

Ref. No.	Parts No.	Description
1	5094-N	Button Clamp Stop Lever
2	5180-N	Knurled Screw for Lever 5094-N
3	123-N	Clamp Screw for Lever 5094-N
4	5181-N	Shoulder Screw for Slide 5093-AN
5	5088-N	Button Clamp Lever Jaws Holder
6	5090-N	Button Clamp Lever Jaw (Left)
7	5092-N	Button Holding Spring (Left)
8	124-N	Screw for Springs 5091-N & 5092-N
9	5089-N	Button Clamp Lever Jaw (Right)
10	5091-N	Button Holding Spring (Right)
11	5189-N	Button Clamp Bearing Screw
12	5093-AN	Button Clamp Slide
13	5182-N	Slotted Nut for Screw 5181-N
14	5179-N	Hinge Screw for Lever Jaws 5089-N & 5090-N
15	5166-N	Button Clamp Spring
16	5086	Button Clamp Holder
17	5177-N	Hexagon Head Screw for Holder 5086
18	5178-N	Washer for Screw 5177-N
19	98-N	Screw for Rod 5154-N
20	5154-N	Button Clamp Lifting Rod
21	5095-A	Button Clamp Pressure Adjusting Screw Stud
22	5096	Spring for Screw Stud 5095-A
23	5095-B	Nut for Screw Stud 5095-A
24	5087-A	Hinge Pin for Holder 5086
25	9082	Ring for Hinge Pin 5087-A
26	5244	Button Clamp Stopper Pin
27	5207	Nut for Stopper Pin 5244
28	5202	Button Tray
29	5231	Pin Leg for Button Tray 5202
30	98	Screw for Pin Leg 5231
31	585-2	Flat Button Clamp Head (Ref. Nos.) 1~15
32	585-N	Flat Button Clamp Complete (Ref. Nos.) 16~20 & 31

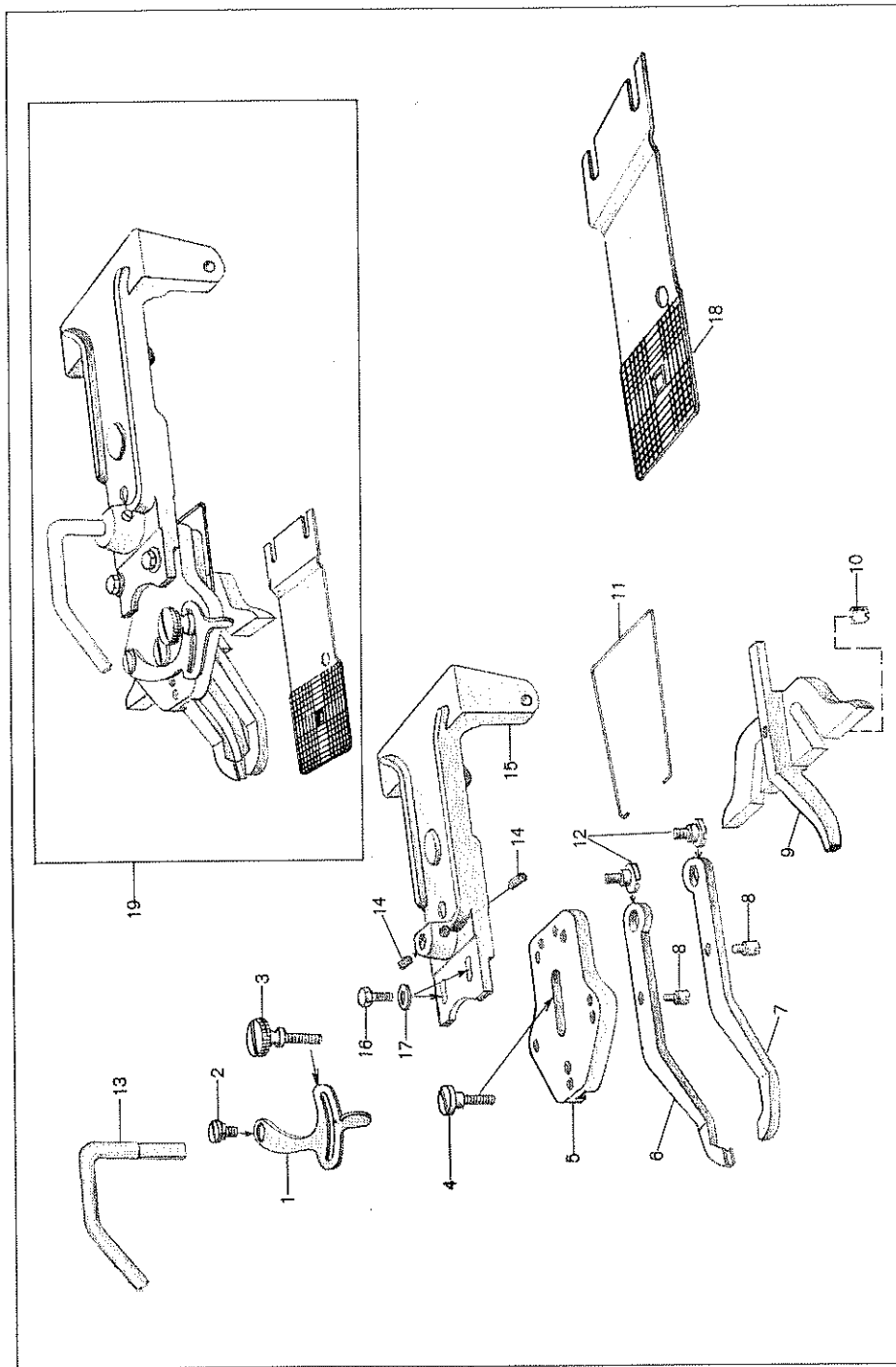

Ref. No.	Parts No.	Description
1	5094-N	Button Clamp Stop Lever
2	5180-N	Knurled Screw for Stop Lever 5094-N
3	123-N	Clamp Screw for Stop Lever 5094-N
4	5181-N	Shoulder Screw for Slide 5093-CN
5	5088-N	Button Clamp Lever Jaws Holder
6	5090-CN	Button Clamp Lever Jaw (Left)
7	5089-CN	Button Clamp Lever Jaw (Right)
8	5189-N	Button Clamp Bearing Screw
9	5093-CN	Button Clamp Slide
10	5182-N	Slotted Nut for Screw 5181-N
11	5166-N	Button Clamp Spring
12	5179-N	Hinge Screw for Lever Jaws
13	5154-N	Button Clamp Lifting Rod
14	98-N	Screw for Rod 5154-N
15	5086	Button Clamp Holder
16	5177-N	Hexagon Head Screw for Holder 5086
17	5178-N	Washer for Screw 5177-N
18	5085-B	Feed Plate for Snap Fastener
19	621-N	Snap Fastener Clamp Complete (Ref. Nos.) 1~18

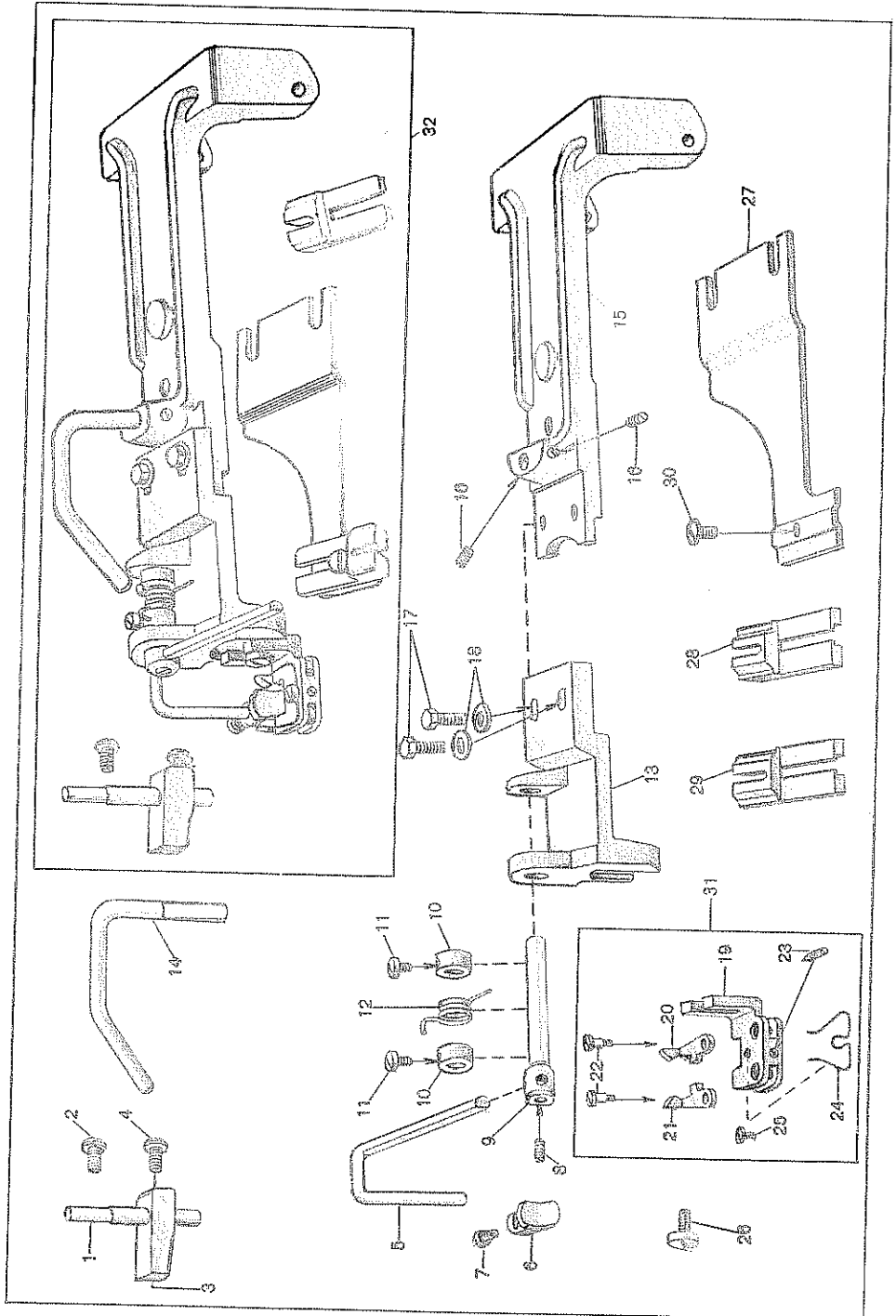

Ref. No.	Parts No.	Description
1	5612	Button Clamp Stud
2	5613	Screw for Stud 5612
3	5611	Button Clamp Block
4	5628	Screw for Block 5611
5	5606	Button Clamp Lever
6	5607	Button Holding Clamp
7	5608	Screw for Clamp 5607
8	5609	Screw for Lever 5606
9	5605	Button Clamp Lever Holding Shaft
10	5602	Collar for Shaft 5605
11	5603	Screw for Collar 5602
12	5604	Spring for Shaft 5605
13	5601	Button Clamp Bracket
14	5154-N	Button Clamp Lifting Rod
15	5086-N	Button Clamp Holder
16	98-N	Screw for Rod 5154-N
17	5177-N	Hexagon Head Screw for Holder 5086-N
18	5178-N	Washer for Screw 5177-N
19	5614	Shank Button Adaptor Base
20	5615	Button Clamp Jaw (Left)
21	5616	Button Clamp Jaw (Right)
22	5617	Screw for Jaws 5615 & 5616
23	5618	Adjusting Screw for Jaws 5615 & 5616
24	5619	Spring for Jaws 5615 & 5616
25	5620	Screw for Spring 5619
26	5610	Screw for Adap or 622-3
27	5621	Feed Palte for Shank Button
28	5623	Work Supporting Block (Medium Step)
29	5624	Work Supporting Block (Low Step)
30	5625	Screw for Work Supporting Block
31	622-3	Adjusting Adaptor Complete (Ref. Nos.) 19~25
32	622-N	Shank Button Clamp Complete (Ref. Nos) 1~30

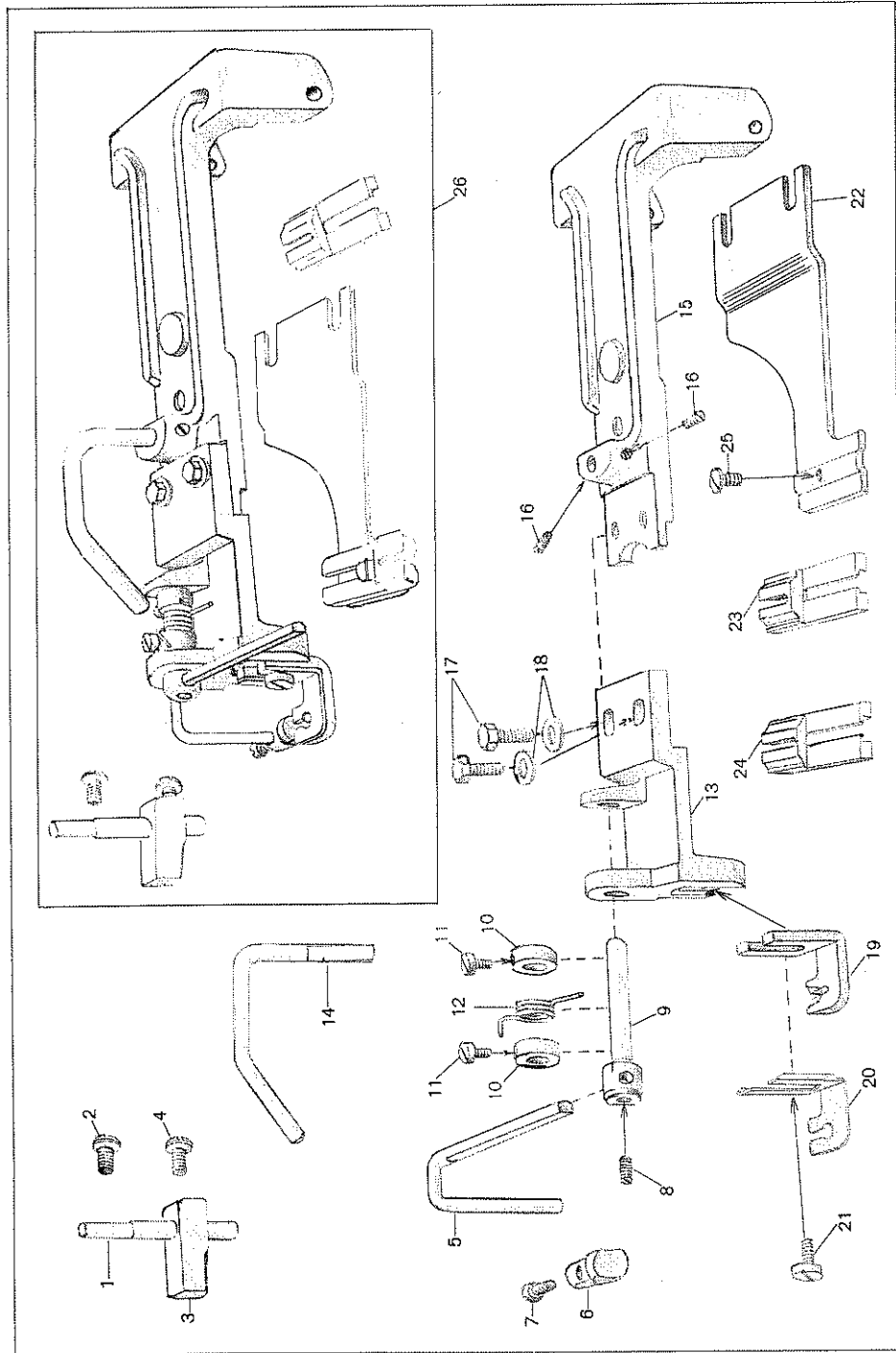

Ref. No.	Parts No.	Description
1	5612	Button Clamp Stud
2	5613	Screw for Stud 5612
3	5611	Button Clamp Block
4	5628	Screw for Block 5611
5	5606	Button Clamp Lever
6	5607	Button Holding Clamp
7	5608	Screw for Clamp 5607
8	5609	Screw for Lever 5606
9	5605	Button Clamp Lever Holding Shaft
10	5602	Collar for Shaft 5605
11	5603	Screw for Collar 5602
12	5604	Spring for Shaft 5605
13	5601	Button Clamp Bracket
14	5154-N	Button Clamp Lifting Rod
15	5086-N	Button Clamp Holder
16	98-N	Screw for Rod 5154-N
17	5177-N	Hexagon Head Screw for Holder 5086-N
18	5178-N	Washer for Screw 5177-N
19	5627	Metal Button Adaptor
20	5626	Metal Button Guard
21	5610	Screw for Adaptor & Guard
22	5621	Feed Plate for Metal Button
23	5623	Work Supporting Block (Medium Step)
24	5624	Work Supporting Block (Low Step)
25	5625	Screw for Work Supporting Block
26	623-N	Metal Button Clamp Complete (Ref. Nos.) 1~25

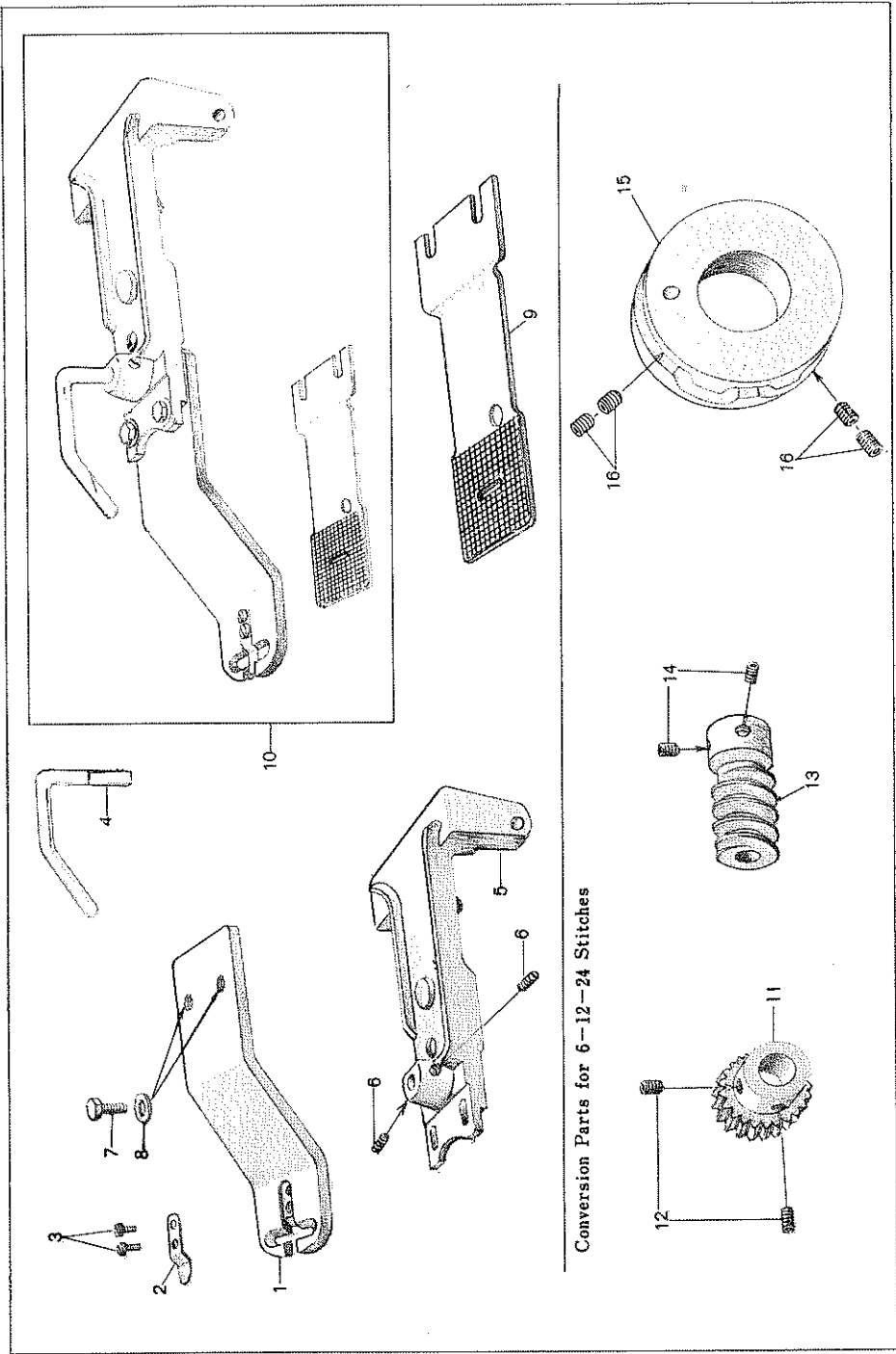

Conversion Parts for 6-12-24 Stitches

Ref. No.	Parts No.	Description
1	5300-A	Label Tacking Clamp
2	5301	Thread Breaking Finger
3	135	Screw for Finger 5301
4	5154-N	Clamp Lifting Rod
5	5086	Label Tacking Clamp Holder
6	98-N	Screw for Rod 5154-N
7	5177-N	Hexagon Head Screw for Holder 5086
8	5178-N	Washer for Screw 5177-N
9	5302	Feed Plate for Label Tacking
10	610-N	Tacking Clamp Complete (Ref. Nos.) 1~9

Conversion Parts for 6-12-24 Stitches

11	5307	Cam Shaft Worm Gear
12	5078-A	Screw for Worm Gear 5307
13	5306	Looper Shaft Worm
14	5251	Screw for Worm 5306
15	5304	Sideways Moving Cam
16	5195-B	Screw for Cam 5304

Parts No.	Page	Parts No.	Page	Parts No.	Page	Parts No.	Page	Parts No.	Page
79-C	3	5028	7	5097	17	5167	11	5232	5
95-B	11	5029-A	17	5098	17	5168	11	5233	1
98	1, 9, 11, 17, 19	5030	15	5099	7, 15	5169	5	5233-A	1
98-A	7	5031	15	5100	17	5170	15	5234	5
98-N	19, 21, 23, 25, 27	5032	15	5101	17	5171-A	15	5235	9
105	5	5033	15	5102	17	5172	15	5236	3
108	5	5034	7	5103	17	5173	15	5237	13
114	3	5035	7	5104-A	17	5174	15	5238	13
115	13	5036	7	5104-B	17	5175	15	5240	13
121	1	5038-A	5	5105	17	5176-A	3, 7, 9	5241	13
121-A	1	5039-A	5, 13	5106	17	5176-B	3	5242	13
121-C	5	5039-B	5	5107	17	5176-C	17	5243	13
123-N	19, 21	5042	1	5108	17	5177	13	5244	19
124-N	19	5043	5	5109	17	5177-N	19, 21, 23, 25, 27	5245	17
129-B	9	5047	7	5110	17	5178	15, 17	5247-A	13
130	7	5048	7	5111	9	5178-N	19, 21, 23, 25, 27	5249	13
131	9, 15, 17	5049	5	5112-A	9	5179-N	19, 21	5250	5
132-A	7, 9, 15	5050	5	5113-A	9	5180-N	19, 21	5251	5, 9, 11, 27
135	27	5051	5	5114	9, 11	5181-N	19, 21	5252	17
507-B	5	5052	5	5115-A	9	5182-N	19, 21	5254	17
555	11	5053	5	5116	9	5183-A	7, 17	5255	17
582	5	5054	5	5117	9	5184	9	5256	17
585-2	19	5055	1	5118	9	5185	13	5263-A	9
585-N	19	5056-A	1	5119	9	5186	15	5264	1
586-T	17	5056-B	1	5120	9	5187	11, 13	5265	9
591	9	5057	3	5121	9	5188	3	5266	9
594	5	5058	3	5122	9	5189-N	19, 21	5267-B	3
596	15	5059	3	5123	9	5190-A	3	5270	15
610-N	27	5060	3	5124	9	5191	17	5271	13
621-N	21	5061	3	5125	9	5192	3	5272	3
622-3	23	5062	3	5126-B	9	5193	13	5273	3
622-N	23	5063	3	5127-A	9	5194	13	5274	3
623-N	25	5064	3	5128	9	5195-B	17, 27	5275	1
4009	13	5065	3	5129	9	5196	5	5276	1
4024	7	5066	7	5130-A	13	5197	13	5277	13
4050	13	5067-A	3	5131	13	5198	13	5300-A	27
4068	5, 11, 13	5068	1	5132	13	5199	13	5301	27
4093-B	13	5069	7	5133	13	5200	3	5302	27
4094	13	5070	13	5134	13	5201	3	5304	27
4095	13	5071	3	5135	13	5202	19	5306	27
4096	3	5072	3	5136	13	5203	1	5307	27
4140	1	5073-A	3	5137-B	13	5204	1	5601	23, 25
4141	1	5074	3	5139	7	5205	1	5602	23, 25
4178	13	5075	3	5140	7	5206	3, 15	5603	23, 25
5001	1	5076	3	5141	7	5207	1, 3, 13, 19	5604	23, 25
5002	1	5077	3	5142	15	5208	3	5605	23, 25
5003	1	5078-A	9, 17, 27	5143	15	5210	1	5606	23, 25
5004	1	5079-B	1	5144	15	5211	5	5607	23, 25
5005	1	5080	17	5145	15	5212-A	5	5608	23, 25
5006	11	5081	17	5146	15	5213-A	1	5609	23, 25
5007	11	5082	17	5147	1	5214	1	5610	23, 25
5008-A	11	5083	17	5148	17	5215	11	5611	23, 25
5009	11	5084	17	5149	17	5216	1	5612	23, 25
5010	11	5085-A	17	5150	1	5217	7	5613	23, 25
5012	11	5085-B	21	5151	1	5218	15	5614	23
5013	7	5086	19, 21, 27	5152	11	5219	17	5615	23
5014	15	5086-N	23, 25	5153-B	1	5220	5	5616	23
5015	15	5087-A	19	5154-N	19, 21, 23, 25, 27	5221	9	5617	23
5016	11	5088-N	19, 21	5155-A	3	5222-B	11	5618	23
5017	11	5089-N	19	5156	1	5223	3	5619	23
5018	11	5089-CN	21	5157	7	5224	9	5620	23
5019	11	5090-N	19	5158	7	5224-A	11	5621	23, 25
5020	11	5090-CN	21	5159	3	5225-B	9	5623	23, 25
5021	11	5091-N	19	5160	3	5225-C	9	5624	23, 25
5022	11	5092-N	19	5161	3	5226	11	5625	23, 25
5023	17	5093-AN	19	5162	3	5227	17	5626	25
5024-A	17	5093-CN	21	5163	13	5228	17	5627	25
5025-A	17	5094-N	19, 21	5164	13	5229	17	5628	23, 25
5026-A	17	5095-A	19	5165-A	11	5230	7	9082	19
5027	17	5095-B	19	5165-C	11	5231	19		
		5096	19	5166-N	19, 21				